

LC15

Monitor Arm

System Oslo

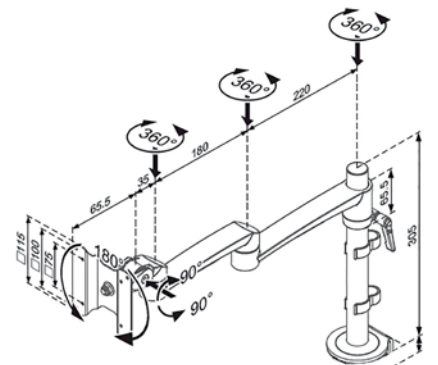

Table clamp max 27 mm

Flexible and steady

A very affordable monitor arm that has become popular for both its clean look and simple function. This can be supplemented by Duo Monitor Bridge for two monitors (c/c max 685 mm), due to a very stable design.



Supplemented with Duo Monitor Bridge for assembly of two monitors.

SPECIFICATIONS

- Flexible with many joints
- Robust and safe
- Maximum arm length 465 mm
- VESA 75/100
- Max load 14 kg.
- Part No. 438-LC15, Silver
Part No. 438-LC15W, White
Part No. 438-LC15B, Black

Accessories

- Part No. 438-LB15,
Duo Monitor Bridge, Silver
- Part No. 438-LB15W,
Duo Monitor Bridge, White